



*Picture for illustrative purposes only

DESIGN SPECIFICATIONS

- ✓ High quality, reliable and complete power unit
- ✓ Compact design
- ✓ Easy start and maintenance
- ✓ Fully tested for load, controls and safety shutdown functions
- ✓ Fully engineered with a range of optional extras and accessories.

400/230V 50 Hz	Generating Set Model		JSP 30
Power Factor 0.8	Prime	kVA	30
		kW	24
	Standby	kVA	33
		kW	26.4

Prime: Continuous running at variable load for unlimited periods with 10% overload available for 1 hour in any 12 hour period. In accordance with ISO 8528, ISO 3046.
Standby: Continuous running at variable load for duration of an emergency. No overload is permitted on these ratings. In accordance with ISO 3046, BS 5514.

TECHNICAL DATA*			
Engine Model	Deutz D2009L04	Alternator	Mecc Alte
Number of Cylinders	4 in-line	Heat Rejection to Exhaust (Max)	17.7 KW
Cubic Capacity	3.2 litre	Heat Rejection to Cooling System (Max)	15.2 KW
Aspiration	Natural	Exhaust Temperature (Max)	550 deg C
Engine Speed (RPM)	1500 rpm	Combustion Air Flow (Max)	2.09 cu m/min
Frequency	50 Hz	Fuel Tank Capacity	100 litre
Amperage	42 amp per phase	Fuel Consumption at Full Prime Rating	6.55 litre per hour

DIMENSIONS*	
Length (A)	1,874 mm
Width (B)	720 mm
Height (C)	1,290 mm
Max Horizontal projection of open door (D)	550 mm
Max total height of open door (E)	2,060 mm
WEIGHT*	
Wet (with lube oil and coolant)	750 kg

SOUND LEVELS*			
Load	15m	7m	1m
100%	60 dB(A)	66 dB(A)	77 dB(A)
75%	59 dB(A)	65 dB(A)	76 dB(A)

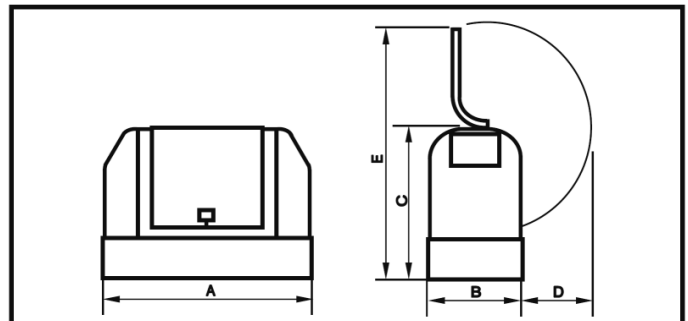

FEATURES*	Manual Start, Main Power Set		Automatic Start, Standby Set	
	Standard	Optional	Standard	Optional
Sound Attenuated, Weatherproof Canopy	✓		✓	
Base Fuel Tank	✓		✓	
Bunded Base Fuel Tank		✓		✓
Oil, Fuel & Air Filters	✓		✓	
Coolant Water Heater			✓	
Lube Oil Drain	✓		✓	
Vibration isolated Control Panel	✓		✓	
Manual Start Control Panel	✓			
Automatic Start Control Panel			✓	
Integral 5A Battery Charger			✓	
Automatic Transfer Panel				✓
12 Months International Warranty	✓		✓	
Output Circuit Breaker	✓		✓	
CE Certification (Standard on UK / EU Models)	✓		✓	
Service / Maintenance Contracts/ Remote Monitoring		✓		✓

*Specifications subject to change without notice

Unit F, Venture Business Park, Witty Street, Hull, East Yorkshire, HU3 4EL, UK

T: +44 (0) 845 430 9110, F: +44 (0) 1482 222646, E: hello@jspower.co.uk, W: www.jspower.co.uk