



*Picture for illustrative purposes only

DESIGN SPECIFICATIONS

- ✓ High quality, reliable and complete power unit
- ✓ Compact design
- ✓ Easy start and maintenance
- ✓ Fully tested for load, controls and safety shutdown functions
- ✓ Fully engineered with a range of optional extras and accessories.

230V 50 Hz	Generating Set Model		JSPSP 10
Power Factor 0.8	Prime	kVA	9.5
		kW	7.6
	Standby	kVA	10.6
		kW	8.5

Prime: Continuous running at variable load for unlimited periods with 10% overload available for 1 hour in any 12 hour period. In accordance with ISO 8528, ISO 3046.
Standby: Continuous running at variable load for duration of an emergency. No overload is permitted on these ratings. In accordance with ISO 3046, BS 5514.

TECHNICAL DATA*			
Engine Model	Perkins 403D-15G	Alternator	Mecc Alte
Number of Cylinders	3 in-line	Heat Rejection to Exhaust (Max)	TBA
Cubic Capacity	1.72 litre	Heat Rejection to Cooling System (Max)	TBA
Aspiration	Natural	Exhaust Temperature (Max)	482 deg C
Engine Speed (RPM)	1500 rpm	Combustion Air Flow (Max)	1.06 cu m/min
Frequency	50 Hz	Fuel Tank Capacity	100 litre
Amperage	41 amps	Fuel Consumption at Full Prime Rating	3.70 litre per hour

DIMENSIONS*	
Length (A)	TBA
Width (B)	TBA
Height (C)	TBA
Max Horizontal projection of open door (D)	TBA
Max total height of open door (E)	TBA
WEIGHT*	
Wet (with lube oil and coolant)	TBA

SOUND LEVELS*			
Load	15m	7m	1m
100%	60 dB(A)	66 dB(A)	77 dB(A)
75%	59 dB(A)	65 dB(A)	76 dB(A)

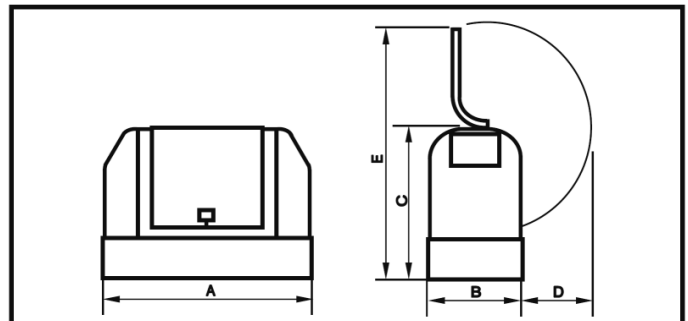

FEATURES*	Manual Start, Main Power Set		Automatic Start, Standby Set	
	Standard	Optional	Standard	Optional
Sound Attenuated, Weatherproof Canopy	✓		✓	
Base Fuel Tank	✓		✓	
Bunded Base Fuel Tank		✓		✓
Oil, Fuel & Air Filters	✓		✓	
Coolant Water Heater			✓	
Lube Oil Drain	✓		✓	
Vibration isolated Control Panel	✓		✓	
Manual Start Control Panel	✓			
Automatic Start Control Panel			✓	
Integral 5A Battery Charger			✓	
Automatic Transfer Panel				✓
12 Months International Warranty	✓		✓	
Output Circuit Breaker	✓		✓	
CE Certification (Standard on UK / EU Models)	✓		✓	
Service / Maintenance Contracts / Remote Monitoring		✓		✓

*Specifications subject to change without notice

Unit F, Venture Business Park, Witty Street, Hull, East Yorkshire, HU3 4EL, UK

T: +44 (0) 845 430 9110, F: +44 (0) 1482 222646, E: hello@jspower.co.uk, W: www.jspower.co.uk